

FRONT BRAKE 2WD (PD60 66 Type Disc) COMPONENTS

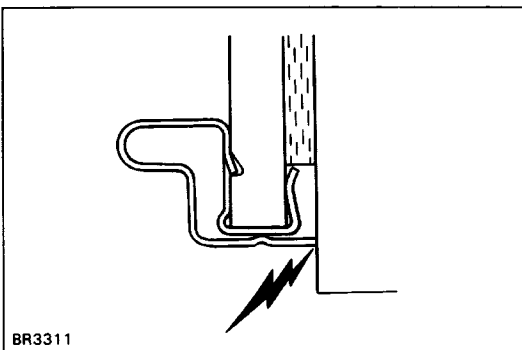
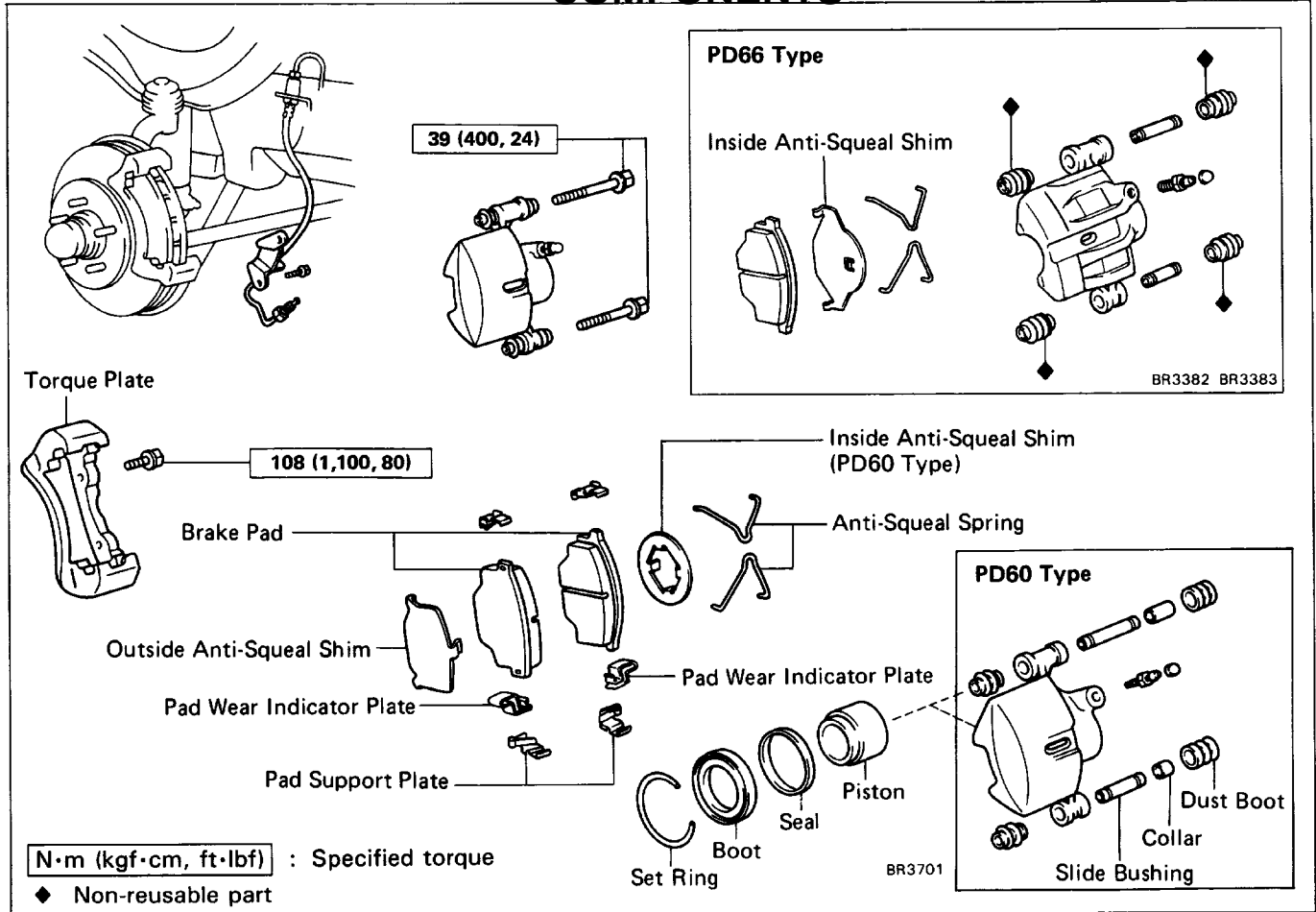

REPLACEMENT OF BRAKE PADS

HINT: If a squealing noise occurs from the front brakes while driving, check the pad wear indicator. If there are traces of the indicator contacting the rotor disc, the brake pad should be replaced.

1. REMOVE FRONT WHEEL

2. INSPECT PAD LINING THICKNESS

Check the pad thickness through the cylinder inspection hole and replace pads if not within specification.

Minimum thickness: 1.0 mm (0.039 in.)

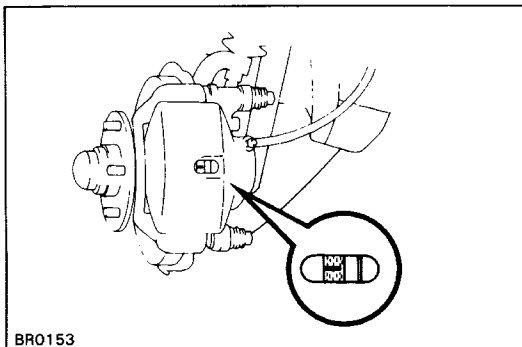

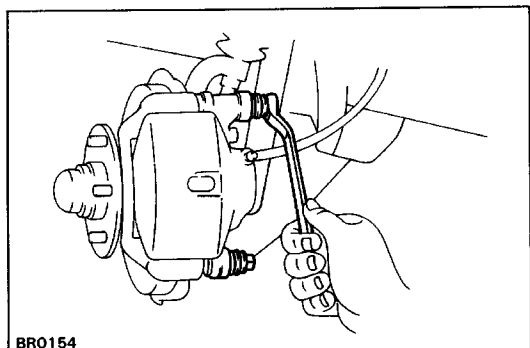

3. LIFT UP CYLINDER

(a) Remove the installation bolt from the torque plate.

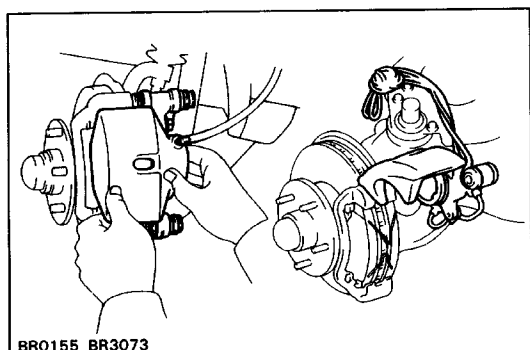

(b) Lift up the brake cylinder and suspend it so the hose is not stretched.

HINT: Do not disconnect the brake hose.

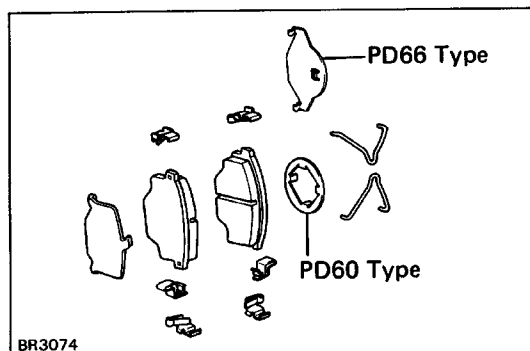

4. REMOVE FOLLOWING PARTS:

- (a) Two anti-squeal springs
- (b) Two brake pads
- (c) Two anti-squeal shims
- (d) Two pad wear indicator plates
- (e) Four pad support plates

5. CHECK ROTOR DISC THICKNESS

(See step 2 on page [BR-23](#))

6. CHECK ROTOR DISC RUNOUT

(See step 3 on page [BR-23](#))

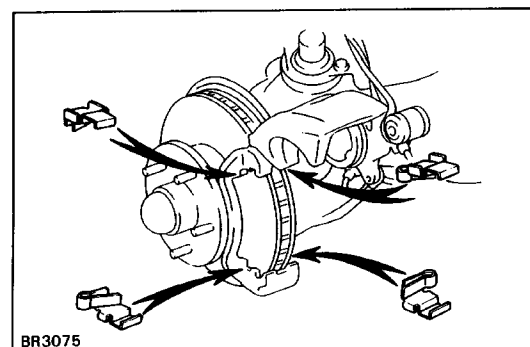

7. INSTALL PAD SUPPORT PLATES

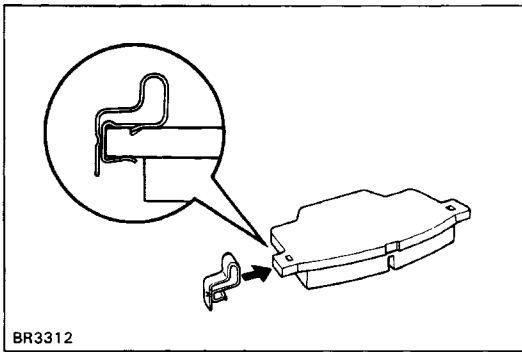

8. INSTALL NEW PADS

- (a) Install a pad wear indicator plate to the pad.
- (b) (PD60 Type)
Install the outside anti-squeal shim to the outside pad.
- (PD66 Type)
Install the two anti-squeal shims to the each pad.

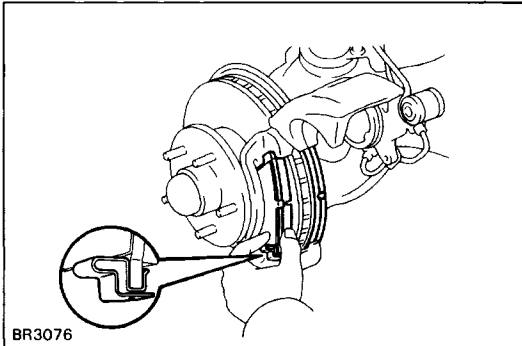

- (c) Install the two pads so the wear indicator plate is facing underneath.
NOTICE: Do not allow oil or grease to get on the rubbing face.
- (d) Install the anti-squeal springs in position.

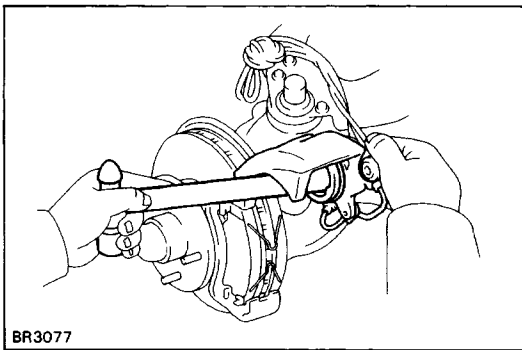

9. INSTALL CYLINDER

- (a) Draw out a small amount of brake fluid from the reservoir.
- (b) Press in piston with a hammer handle or an equivalent.
HINT: Always change the pad on one wheel at a time as there is a possibility of the opposite piston flying out.

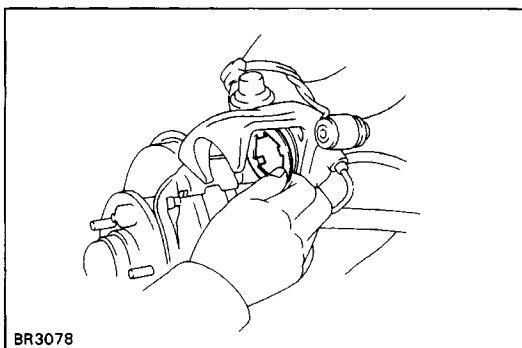

- (c) (PD60 Type)
Install the inside anti-squeal shim to the piston.
- (d) Insert the brake cylinder carefully so the boot is not wedged.

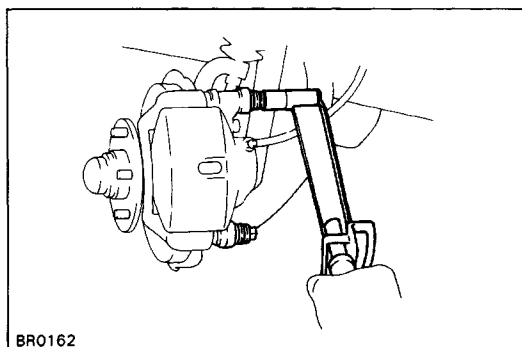

- (e) Install and torque the installation bolts.
Torque: 39 N-m (400 kgf-cm, 29 ft-lbf)

10. INSTALL FRONT WHEEL

11. CHECK THAT FLUID LEVEL IS MAX LINE

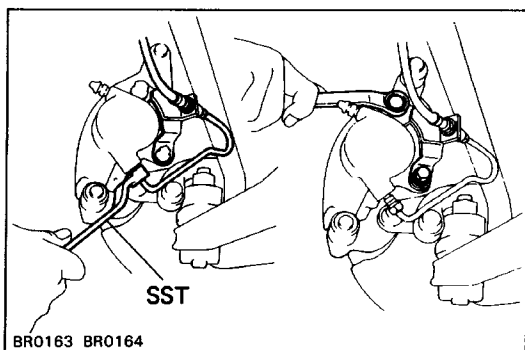

REMOVAL OF CYLINDER

(See page [BR-18](#))

1. DISCONNECT BRAKE TUBE

- (a) Using SST, disconnect the brake tube. Use a container to catch the brake fluid.
SST 09751-36011
- (b) Remove the bracket from the cylinder.

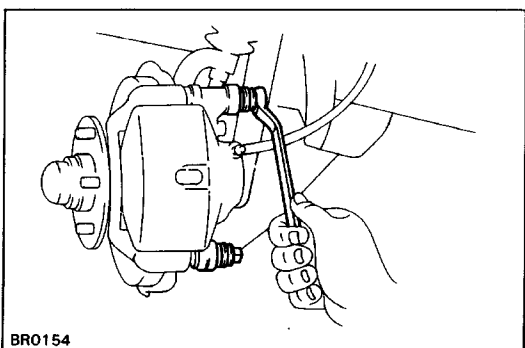

2. REMOVE CYLINDER FROM TORQUE PLATE

Remove the two installation bolts and cylinder.

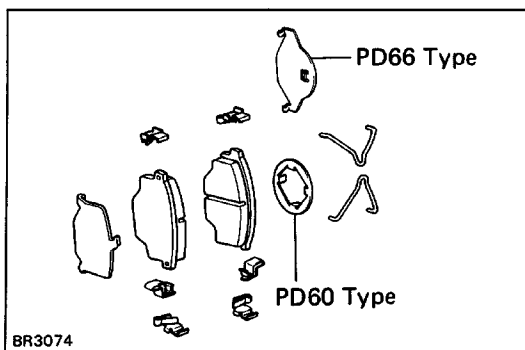

3. REMOVE PADS

(See step 4 on page [BR-19](#))

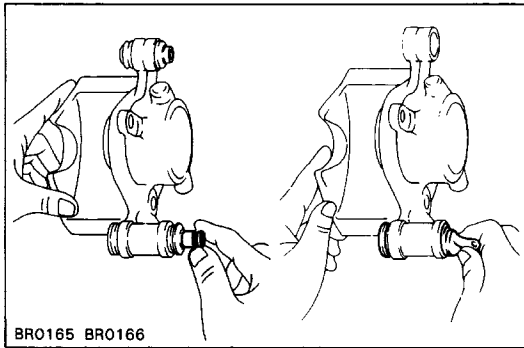

DISASSEMBLY OF CYLINDER

(See page [BR-18](#))

1. (PD60 TYPE)

REMOVE CYLINDER SLIDING BUSHINGS, DUST BOOTS AND COLLARS

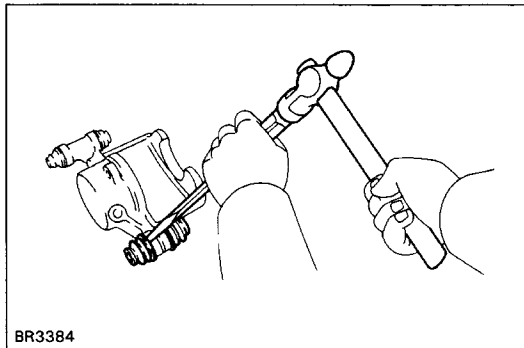

(PD66 TYPE)

REMOVE CYLINDER SLIDING BUSHINGS AND DUST BOOTS

- (a) Remove the sliding bushings.
- (b) Using a chisel and a hammer, remove the dust boots.

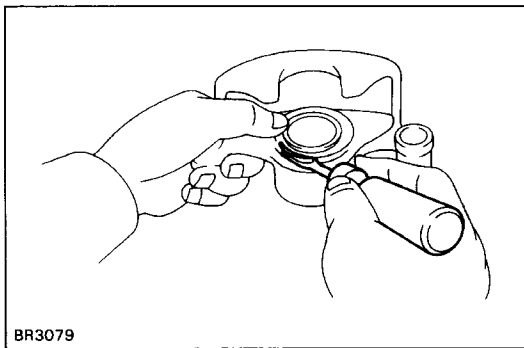

2. REMOVE CYLINDER BOOT SET RING AND CYLINDER BOOT

Using a screwdriver, remove the cylinder boot set ring and cylinder boot.

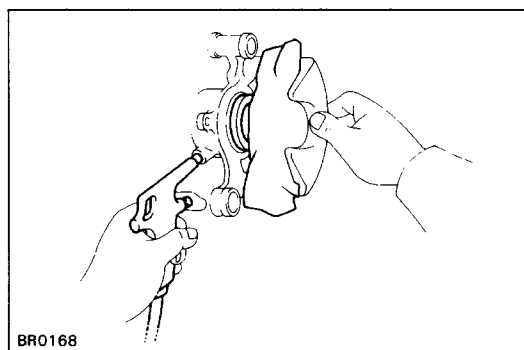

3. REMOVE PISTON FROM CYLINDER

- (a) Put a piece of cloth or an equivalent between the piston and cylinder.
- (b) Use compressed air to remove the piston from the cylinder.

NOTICE: Do not place your fingers in front of the piston when using compressed air.

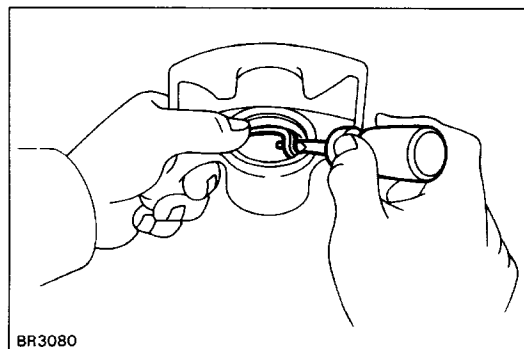

4. REMOVE PISTON SEAL FROM BRAKE CYLINDER

Using a screwdriver, remove the piston seal.

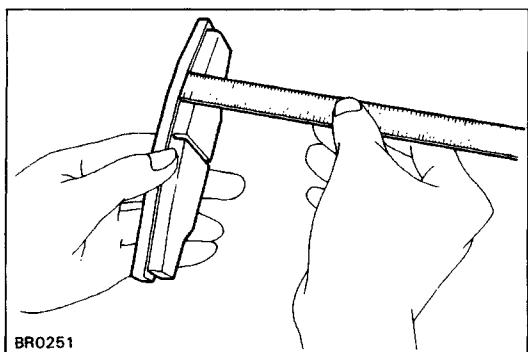

INSPECTION OF FRONT BRAKE COMPONENTS

1. MEASURE PAD LINING THICKNESS

Standard thickness:

PD60 Type 9.5 mm (0.374 in.)

PD66 Type 9.7 mm (0.382 in.)

Minimum thickness: 1.0 mm (0.039 in.)

Replace the pad if the thickness is less than the minimum (the 1.0 mm slite is no longer visible), or if it shows sign of uneven wear.

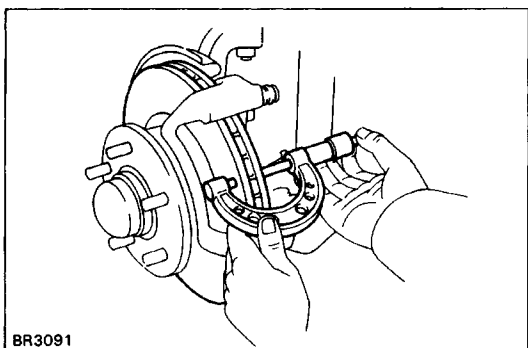

2. MEASURE ROTOR DISC THICKNESS

Standard thickness:

PD60 Type 25.0 mm (0.984 in.)

PD66 Type 30.0 mm (1.181 in.)

Minimum thickness:

PD60 Type 23.0 mm (0.906 in.)

PD66 Type 28.0 mm (1.102 in.)

If the disc is scored or worn, or if thickness is less than minimum, repair or replace the disc.

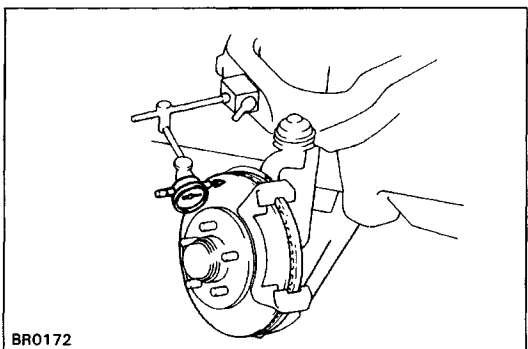

3. MEASURE ROTOR DISC RUNOUT

HINT: Before measuring the runout, confirm that the front hub bearing play is within specification.

Measure the rotor disc runout at 10 mm (0.39 in.) from the outer edge of the rotor disc.

Maximum disc runout:

PD60 Type 0.09 mm (0.0035 in.)

PD66 Type 0.12 mm (0.0047 in.)

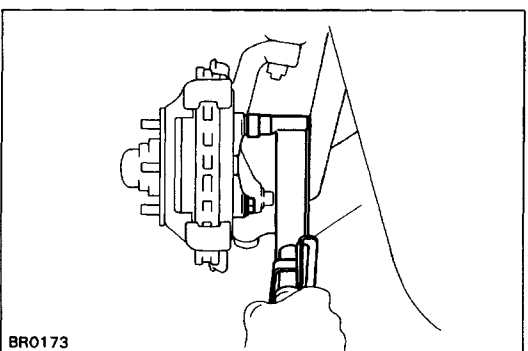

4. IF NECESSARY, REPLACE ROTOR DISC

(a) Remove the torque plate from the knuckle.

(b) Remove the axle hub. (See page [SA-15](#))

(c) Remove the disc from the axle hub.

(d) Install a new rotor disc. Torque the bolts.

Torque: 64 N-m (650 kgf-cm, 47 ft-lbf)

(e) Install the axle hub and adjust the front bearing preload. (See page [SA-16](#))

(f) Install the torque plate onto the knuckle.

Torque: 108 N-m (1,100 kgf-cm, 80 ft-lbf)

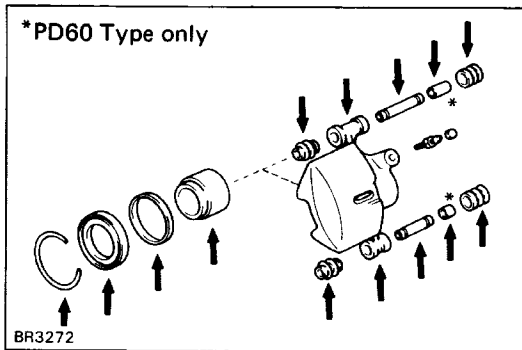

ASSEMBLY OF CYLINDER

(See page [BR-18](#))

1. APPLY LITHIUM SOAP BASE GLYCOL GREASE TO PARTS INDICATED WITH ARROWS

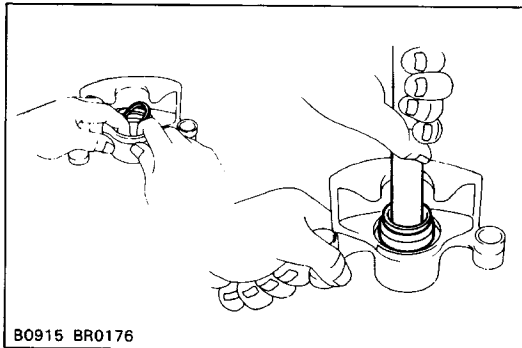

2. INSTALL PISTON SEAL AND PISTON IN CYLINDER

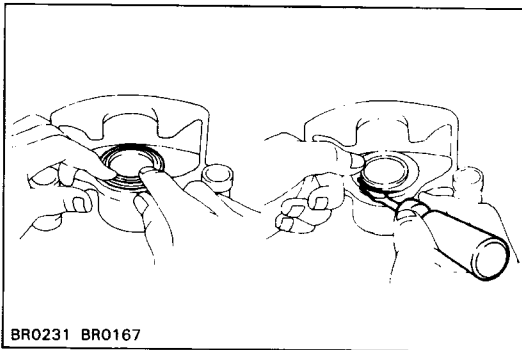

3. INSTALL CYLINDER BOOT AND SET RING IN CYLINDER

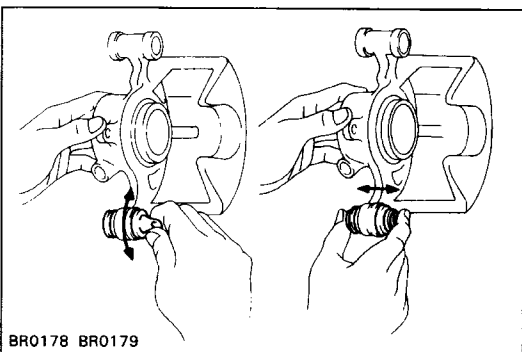

4. (PD60 TYPE)

INSTALL COLLAR, DUST BOOTS AND CYLINDER SLIDING BUSHINGS

- (a) Install the collar and dust boots into the brake cylinder.
- (b) Insure that the boots is secured firmly to the brake cylinder grooves.
- (e) Install the bushing into the boots.
- (d) Insure that the boots is secured firmly to the bushing grooves.

(PD66 TYPE)

INSTALL DUST BOOTS AND CYLINDER SLIDING BUSHINGS

- (a) Using two socket wrenches and a vise, press in new dust boots.
- (b) Install the bushing into the boots.
- (c) Insure that the boots is secured firmly to the bushing grooves.

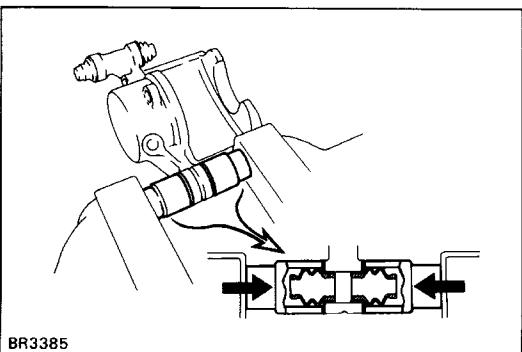

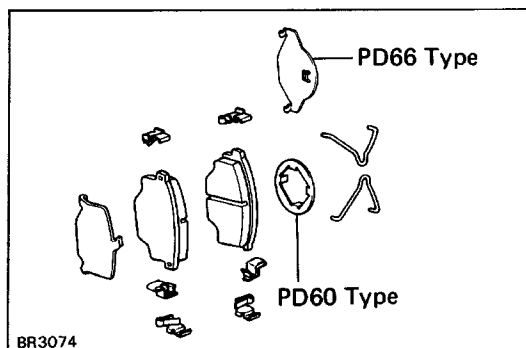

INSTALLATION OF CYLINDER

(See page [BR-18](#))

1. INSTALL PADS

(See steps 7 to 8 on pages [BR-19](#) and 20)

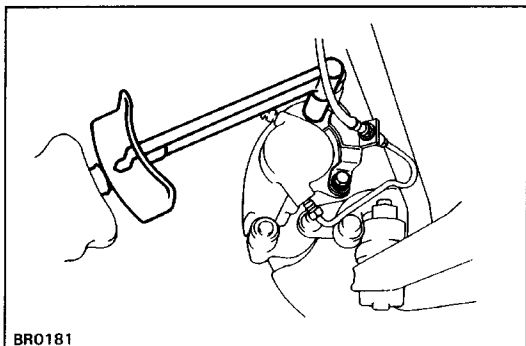

2. INSTALL CYLINDER

- (a) Insert the brake cylinder.
- (b) Install and torque the two installation bolts.
Torque: 39 N-m (400 kgf-cm, 29 ft-lbf)

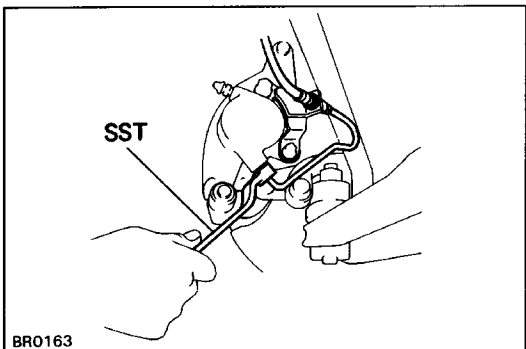

3. INSTALL BRAKE TUBE TO BRAKE CYLINDER

- (a) Install the bracket to the cylinder.
Torque: 18 N-m (185 kgf-cm, 13 ft-lbf)
- (b) Using SST, connect the brake tube to the cylinder.
SST 09751-36011
Torque: 15 N-m (155 kgf-cm, 11 ft-lbf)

4. FILL BRAKE RESERVOIR WITH BRAKE FLUID AND BLEED BRAKE SYSTEM

(See page [BR-8](#))

5. CHECK FOR FLUID LEAKAGE